

.....  
Targeted  
treatment for  
Rising Damp  
.....



• F A S T • C L E A N • E F F E C T I V E •



**DRYZONE**  
Targeted Treatment for Rising Damp.

The cream of  
Rising Damp  
treatment  
for the  
21st Century:

- Quick to install
- Concentrated formulation
- Low hazard
- Spillage and mess virtually eliminated
- Consistent application rate
- Does not require an electric DPC pump



**Dryzone on site.**

A damp course being installed using Dryzone cream, at Pembroke Lodge, Richmond Park by Warren Woodworm Ltd.

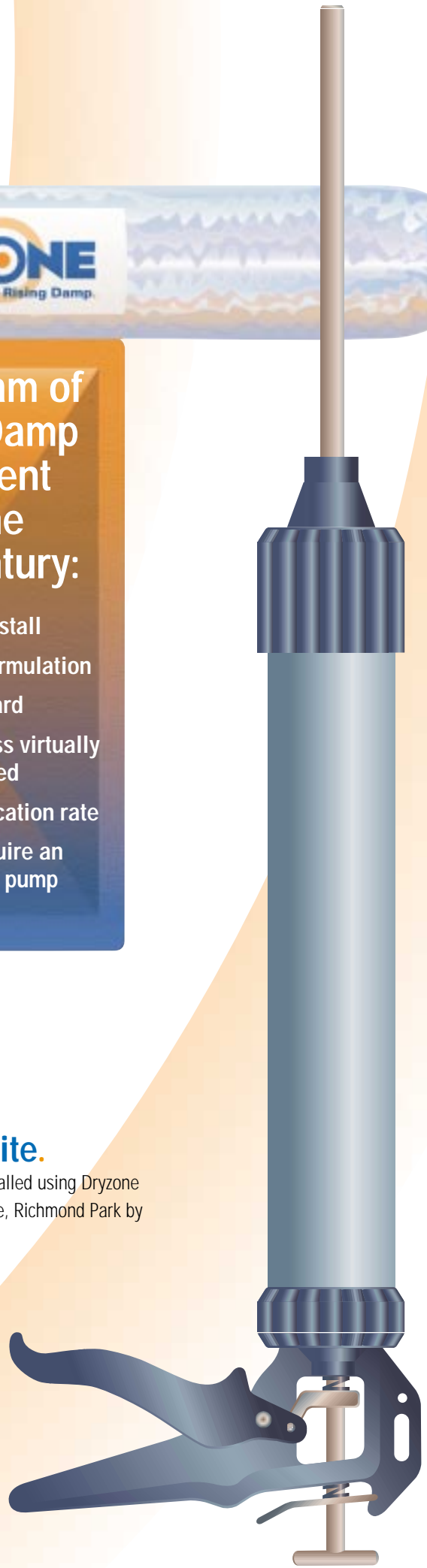

• F A S T • C L E A N • E F F E C T I V E •

# DRYZONE

Targeted Treatment for Rising Damp.

## ◉ The Problem.

Whenever Rising Damp is diagnosed, it is important to have the condition correctly treated, as failure to do so can cause damage and devaluation to any property.

It is not sufficient to simply cover up the problem with a special paint or coating in the hope that the problem will go away. Only by preventing the dampness rising up the wall in the first place can rising dampness be adequately controlled.

## ◉ Chemical Treatments.

Up until now, the most widely employed method of achieving this has been to inject water-repellent fluids into the wall under pressure.

Although this method has proven to be effective, it is known to have a number of disadvantages; for example, it introduces large amounts of liquid carrier into the wall, prolonging the drying out period. The process is also very slow and operator dependent.

## ◉ The Dryzone System is fast, clean and effective.

Dryzone is a revolutionary new material for the control of rising damp. Dryzone comes in the form of a water-repellent cream packed in a 600ml foil cartridge to minimise environmental impact. The Dryzone cream is introduced by means of a simple applicator gun into a series of holes drilled into the mortar course. Once the Dryzone is installed, it uses the moisture contained in the damp wall to diffuse where it is most needed before curing to form a water-repellent resin.

Dryzone in action:

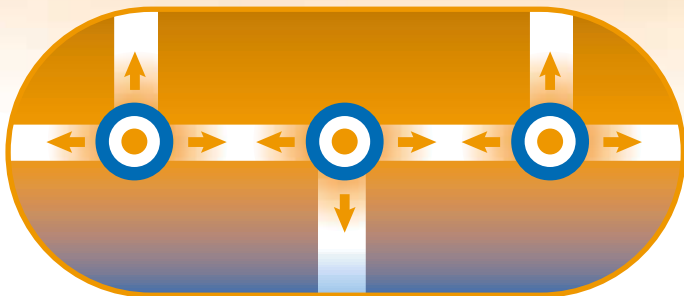

## Dryzone has many advantages over conventional chemical injection systems:

- ◉ Quick to install - no "double drilling", no waiting for fluid to soak in under pressure.
- ◉ Easy to install - less scope for operator error
- ◉ Concentrated formulation (over 60% active ingredient) - does not introduce large volumes of liquid carrier into the wall.
- ◉ Low hazard - non-caustic, non-flammable not injected under pressure.
- ◉ Spillage and mess virtually eliminated - no problems with fluid flooding through party walls.
- ◉ Consistent application rate - easy to estimate the amount of material that will be required.
- ◉ Does not require an electric DPC pump - can be used in situations where power is not available.

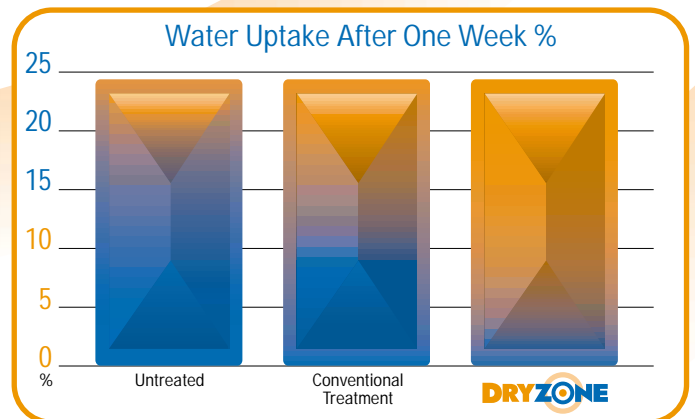

## ◉ Superior Performance.

Dryzone is the result of an extensive in-house research and development programme. This involved the screening and testing of hundreds of potential formulations.

These tests demonstrate that Dryzone offers a higher degree of protection against rising damp than the chemical injection systems that it was designed to replace.

A paper describing the development of Dryzone was recently presented to the British Wood Preserving and Damp-Proofing Association (BWPDA) convention. Copies are available directly from the BWPDA - telephone (01332) 225100.

## ○ Your Guarantee.

The Dryzone system is recognised by both the Guarantee Protection Trust (GPT) and the Property Guarantee Administration (PGA) as an acceptable method of rising damp treatment.

The GPT and PGA are the industry leaders in the provision of independent, long-term guarantee insurance for remedial treatments.

Ask your contractor about the GPT and PGA schemes, or call one of the following numbers:

Property Guarantee Administration:

0870 607 1610

Guarantee Protection Trust:

01494 447 049



## ○ The Environment.

Dryzone was designed with the environment in mind. Its concentrated formulation means that less product has to be transported to the point of use and minimal packaging means less wastage.

The formulation is based on silicones. These are derived from quartz and are widely used to manufacture a wide variety of products from medical instruments to cosmetics and sealants.

Dryzone is water-based and contains no hydro-carbon solvents.

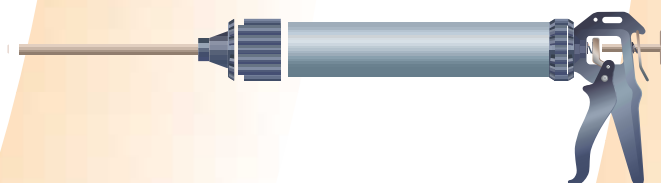

## Dryzone installation instructions: 1.0 The drilling programme.

### 1.1 Drill hole size, depth and location.

For treatment to be fully effective the correct volume of Dryzone must be introduced. The system requires 12-mm diameter holes to be drilled at horizontal centres no greater than 120 mm. The depth of hole required for various thickness of wall is shown in the table below. For all other walls the depth of hole should be to within 40 mm of the opposite face. In all cases the most effective target site is to drill horizontally, directly into the mortar course, preferably at the base of all perpend of the course selected (see diagram).

Depth of 12 mm drill hole required for Dryzone in various thickness of wall:

Wall thickness	4 1/2" (110 mm)	9" (220 mm)	13 1/2" (330 mm)	18" (440 mm)
Depth of hole required	100 mm	190 mm	310 mm	430 mm
Hole centres	120 mm	120 mm	120 mm	120 mm

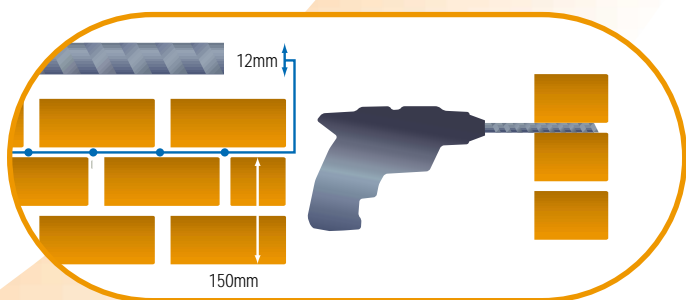

### How many tubes of Dryzone do I need

Wall thickness	4 1/2" (110 mm)	9" (220 mm)	13 1/2" (330 mm)	18" (440 mm)
Length of wall				
10m	1.5	3.0	5.1	7.0
20m	3.0	6.0	10.2	13.0
30m	4.6	9.0	15.3	21.0
40m	6.1	12.0	20.4	28.0

Note: different site conditions may cause slight variations. Allow an extra 10% when estimating.

### 1.2 Preparation.

As necessary remove skirting boards and/or render/plaster to identify and expose the appropriate mortar course to be targeted for treatment. Measure the thickness of each wall to be treated. Set the depth gauge of the drill or apply tape to the drill bit in order to identify the correct drilling depth accordingly.

### 1.3 Solid brick walls.

In virtually all cases solid brick walls may be drilled/treated from one side only in a single operation. Drill the selected mortar course at the prescribed centres to the appropriate depth in accordance with 1.1 (above left).

### 1.4 Cavity walls.

Cavity walls may be drilled/treated from one side in a single operation or if preferred each leaf may be treated separately. When undertaking treatment from one side drill completely through the selected mortar course, allow the drill bit to pass across the cavity and then drill the other leaf of brickwork to a depth of 90 mm. The viscosity of Dryzone is such that it is possible to treat each leaf from a single drilling operation. Always ensure that the cavity is clear before treatment.

### 1.5 Random stone and rubble infill walls.

As far as practically possible follow the mortar course at the appropriate selected level. If the stone is of a porous type e.g. sandstone then there is no reason why this should not be drilled. The variable thickness of stone walls and the possibility of rubble infill dropping and blocking injection holes cause difficulties for any system. Should these difficulties occur it may be necessary to drill to 50% of the wall thickness, from both sides at a corresponding height. Alternatively drill additional holes, adjacent to obstructed holes to ensure that an adequate volume of Dryzone is introduced.

## 2.0 The injection process and making good.

### 2.1 Dryzone cartridge preparation.



**A** Press lever clasp release and pull pressure piston out to maximum position.

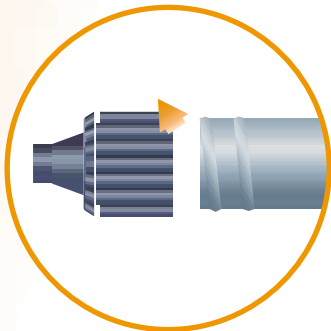

**B** Unscrew and remove delivery tube end of the Dryzone application gun.

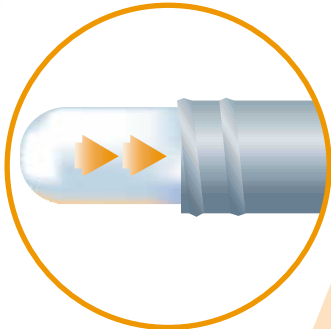

**C** Insert Dryzone cartridge into the barrel of the gun.

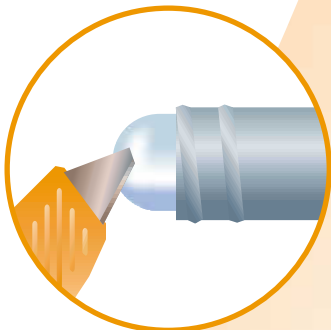

**D** Cut or puncture the visible end of cartridge in the barrel.

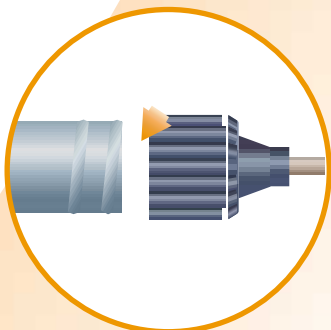

**E** Replace delivery tube end of application gun.

### 2.2 Dryzone injection.

Insert delivery tube of Dryzone application gun into the full depth of the pre-drilled hole. Squeeze the gun trigger and back fill each hole fully with Dryzone to within one centimetre of the surface. When treating cavity walls from one side make certain that the holes in

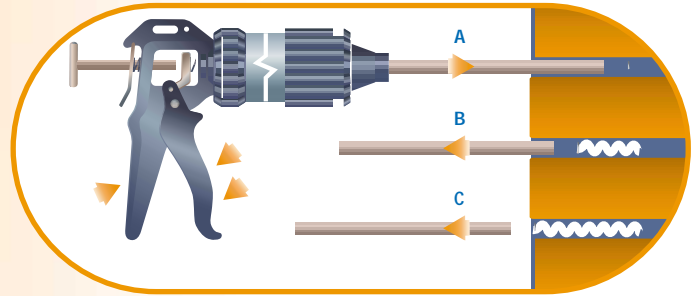

each leaf are filled. Dispose of used cartridges in a plastic bag in accordance with local waste disposal regulations.

### 2.3 Making good.

All drilled holes should either be plugged or pointed over.

### 2.4 Replastering.

In common with all remedial damp proof course systems the adequate removal and correct replastering of internal salt contaminated plaster is an essential requirement. The recommended replastering specification for this is outlined in the Safeguard Renderguard Gold data sheet or the Safeguard publication 'Rising Damp and its Control'.

## 3.0 General information.

### 3.1 Accidental spillage.

In the event of any accidental spillage of Dryzone, the spilt material should be wiped up immediately and the wipes placed in a plastic bag and disposed appropriately. Contaminated surfaces should be washed immediately with warm soapy water.

### 3.2 Health and Safety.

Wear nitrile or similar gloves. Avoid contact with skin. Wear suitable eye protection. Full health and safety data sheet is available on request.

### 3.3 BS 6576: 1985.

In all cases the new damp proof course should, as far as practically possible, be installed in accordance with the British Standard Code of practice for 'Installation of Chemical Damp Proof Courses' BS 6576 (1985).

### 3.4 Caution.

Dryzone can sometimes spread through wet plaster.

Dryzone has not been designed for surface application and should not be used for this purpose. Some white surface stain may occur around the injection site. Should this occur it will brush off when dry.



## Precautions.

Read instructions and health and safety data sheet (available on request) before use.

## Packaging.

Dryzone is packed in boxes of 10 x 600ml foil cartridges.

## Storage.

Store in a cool, dry place.  
Protect from frost.

## Further information.

The Dryzone manual, 'Rising damp and its control,' is available on request, or can be downloaded free from our web site.

[www.safeguardchem.co.za](http://www.safeguardchem.co.za)



Safeguard Chemicals SA (Pty)Ltd.

PO Box 1032

Sundowner

2161

Johannesburg

South Africa

Tel: (011) 708 3603

Fax: (011) 708 3620